

Composite dry sliding bushings, Composite dry sliding flanged bushings

Principal dimensions					Basic load ratings				Mass	Designation
d	D	D1	B	B1	radial dynamic C	static C0	axial dynamic Ca	static C0	kg	-
mm					kN					
20	23	30	11,5	1,5	14,3	45	17,3	54	0,013	PCMF 202311.5 E

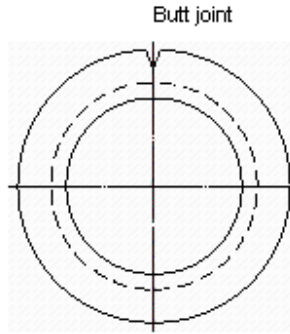
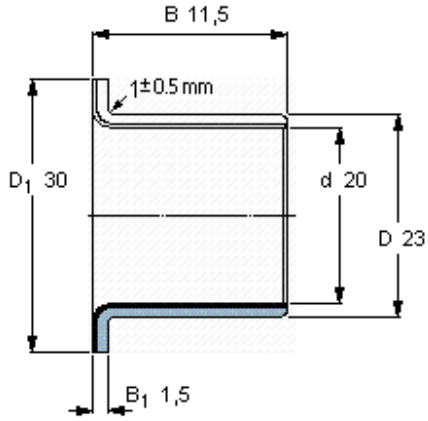

Specific load factor
Material constant

K 80
K_M 480